

VERTICAL COASTLINE INSTALLATION GUIDE

ISSUE 1



CONTENTS

1. Pre-Installation	2
2. Product suitability	5
3. Building Regulations	5
4. Storage and handling	5
5. Fixing timber battens	6
6. Fixing of first trims	8
7. Cladding board fixing method	18
8. End closer trims	21
9. Final inspection - thing to look for	28
10. General maintenance	28
11. Surface repair	28
12. Board replacement procedures	28



BE SAFE WHEN WORKING AT HEIGHT

Ensure you conform to the latest Work at Height Regulations. For more details, visit:
www.hse.gov.uk/work-at-height

If in doubt at any stage

Please contact the customer services department.



0800 988 7309



customer@deeplas.co.uk

PRE-INSTALLATION

1. PRE-INSTALLATION

PRE-INSTALLATION CHECK



▶ Coastline Cladding is designed for use on masonry buildings with a maximum height of 11m and must be installed at least 1 metre from boundaries.

Failure to install Vertical Coastline in accordance to these instructions will invalidate the Product Guarantee.

COMPONENTS

CLV180
Vertical Cladding
Plank (All Colours)

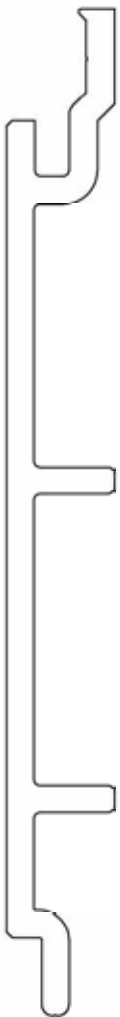

CLV054
End Closer / Reveal Receiver
(Aluminium)
(Mill)

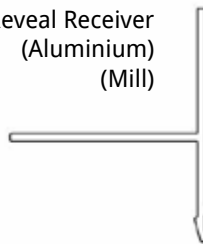

CLV064
End Closer Cover Trim
(Aluminium)
(All Colours)

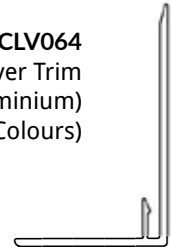

CL014
Starter / Head Bar / Dormer Trim
(Aluminium)
(All Colours)

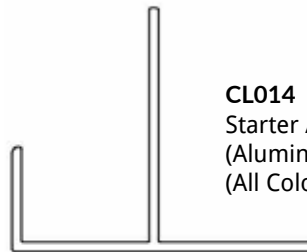

CLV058
Window Reveal Cover Trim
(Aluminium)
(All Colours)



CL009
Window Reveal Trim
(All Colours)



COMPONENTS

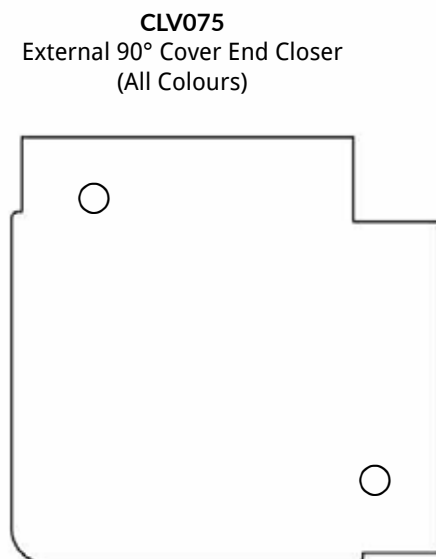
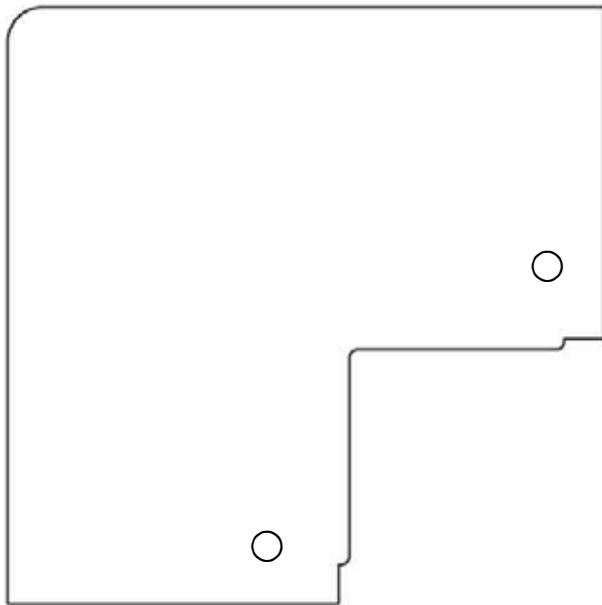
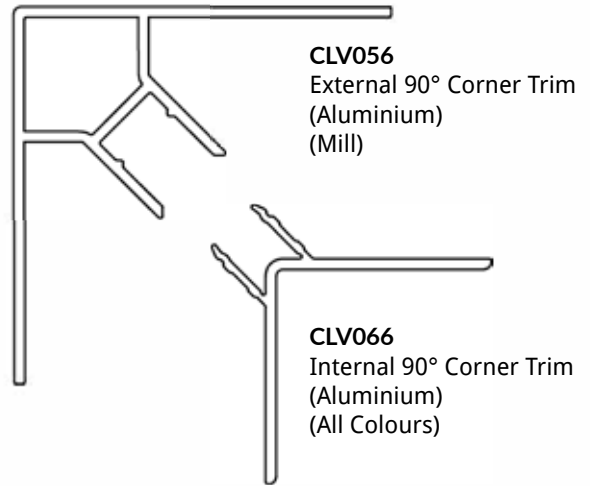
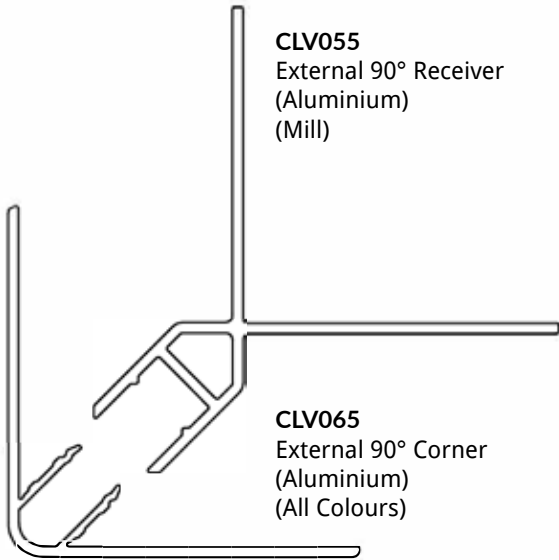

VERTICAL COASTLINE CLADDING BOARD COVERAGE

Each Vertical Coastline Cladding Board has a seen face of 150mm width. Each 5m board will give approximately 0.75m² (150mm x 5000mm) so each pack of 4 = 3m² coverage approximately.

These dimensions serve as a guide and will differ due to the amount of apertures within the wall construction.

VERTICAL COASTLINE CLADDING ANCILLARIES

Silicone		
CODE	COLOUR	RAL CODE
SILIRUBCOLORPG	PEBBLE GREY	RAL 7032
SILIRUBCOLORGY3	WINDOW GREY	RAL 7040
SILI2ANGY	ANTHRACITE GREY	RAL 7016

Touch Up Pens	
CODE	COLOUR
EWS701GR7016	ANTHRACITE GREY
EWS701GR7155	MOONDUST GREY
EWS701SG	SOFT GREEN

Fixing Nails		
CODE	DESCRIPTION	SIZE
CL090	COASTLINE FIXING NAILS (A4 316 STAINLESS STEEL)	3mm x 25mm x 7.5mm
CL091	COASTLINE SELF TAP SCREW	4mm x 25mm

VERTICAL COASTLINE CLADDING

Cladding		
CODE	COLOUR	RAL CODE
CVL180GY1	ANTHRACITE GREY GY1	RAL 7016
CVL180SG	SOFT GREEN SG	RAL 7032
CVL180GY3	MOONDUST GREY GY3	RAL 7040

2. PRODUCT SUITABILITY

Coastline Cladding is designed for use on **masonry buildings with a maximum height of 11m and must be installed at least 1 metre from boundaries**. It should not be fitted to higher buildings, timber buildings or steel construction dwellings, all product guarantees will be invalidated should this occur. Coastline Cladding can be fitted to garden buildings which are not habitable dwellings for living 24/7.

Note: Installation in areas outside of Northern European Climates will invalidate the Product Guarantee.

Coastline Composite Cladding needs to be fitted as outlined within this installation guide. Non adherence to these instructions, and good fitting practices will invalidate the product guarantee. Correct use of all Coastline components, and sundries is also required, use of modified or non specified components will invalidate the Product Guarantee.

3. BUILDING REGULATIONS

The four geographic regions to which the Building Regulations apply, namely England, Wales, Scotland and Northern Ireland, each have their own provision for achieving an acceptable standard of fire protection. Building Regulations in the UK apply to most new

buildings and many refurbishments of existing structures and compliance to all aspects, including fire regulations, is a legal requirement. **Combustible systems less than 11m in height and greater than 1 metre from a boundary require no special fire provisions.**

4. STORAGE AND HANDLING

- ▶ Coastline Cladding planks and aluminium trims must be stored under cover, ideally indoors and away from direct sunlight.
- ▶ Profiles should be stocked and transported horizontally.
- ▶ Ensure profiles are secured during transportation to avoid scratching.
- ▶ Coastline Cladding Planks should be lifted from the stack rather than dragged as this can result in damage to the surface finish.
- ▶ When carrying the cladding planks hold the edges vertically to avoid bending the plank.
- ▶ Do not drag the aluminium sections from the stillage as this could scratch the powder coat finish.

INSTALLATION PROCESS

For the purpose of this guide we will break it down into the following stages.

1. Fixing of timber battens
2. Fixing of first trims
3. Cladding board fixing
4. Fixing of cover trims

Please read this guide in full prior to commencing installation. Additional scenarios can be found at the end.

INSTALLATION GUIDE

5. FIXING TIMBER BATTENS

5.0

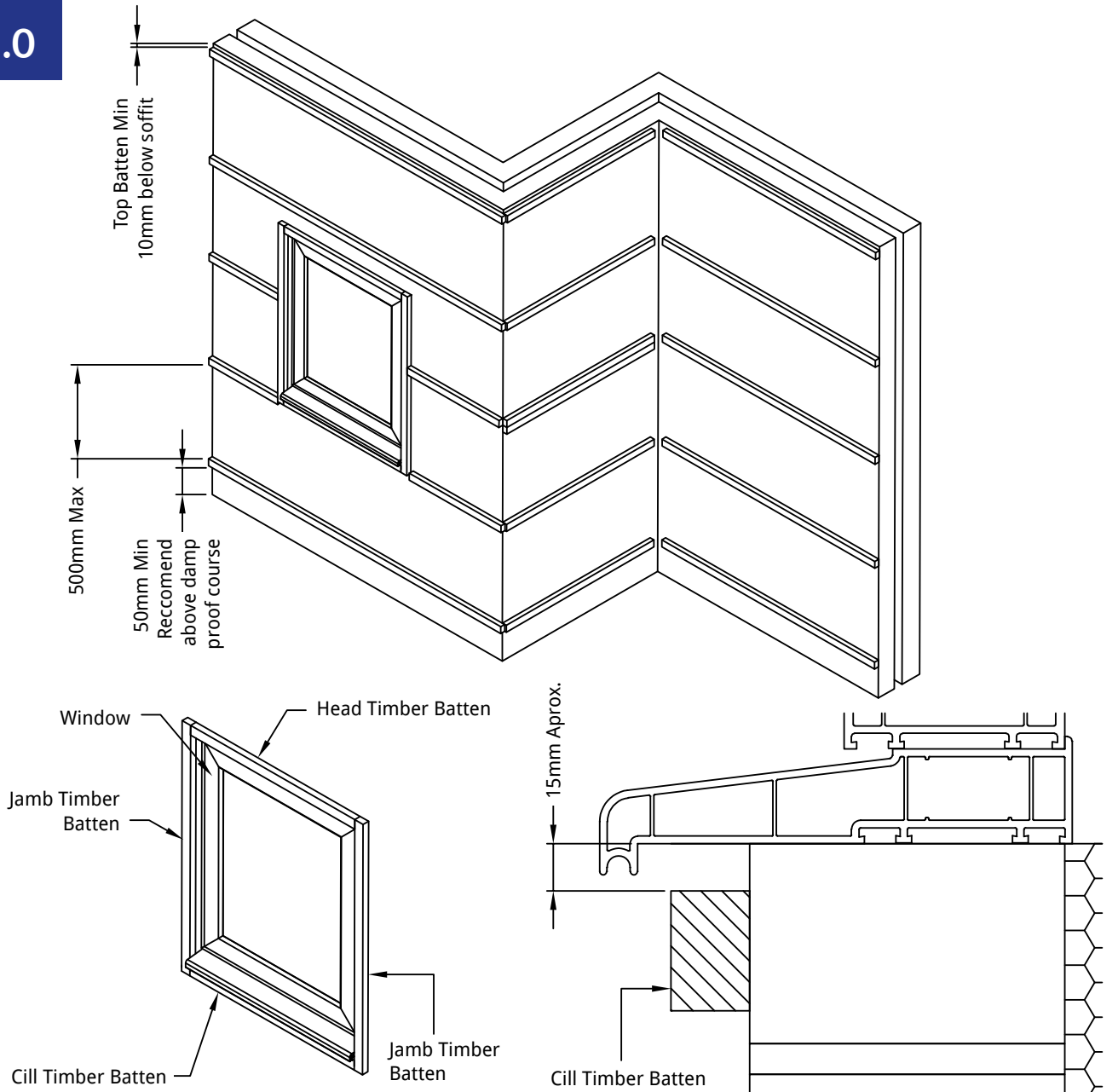

Position and fix the timber battens (38mm x 25mm) to the wall using stainless steel screws. Battens to run horizontally starting at a minimum of 50mm from the bottom of the brickwork/ Substrate. Where a damp proof course is present it is recommended to start the cladding above this point.

Batten centres to be spaced at a maximum 500mm apart.

Two timber battens are required side by side where a Butt Joint (CL007) is located, this is to allow the Butt Joint to be fixed to the timbers correctly.

Timber battens are required on all four sides of the window.

5.1

When using an External Corner Trim extend the timber battens to finish flush with the adjacent battens as shown below. This will allow for better fixing of the receivers.

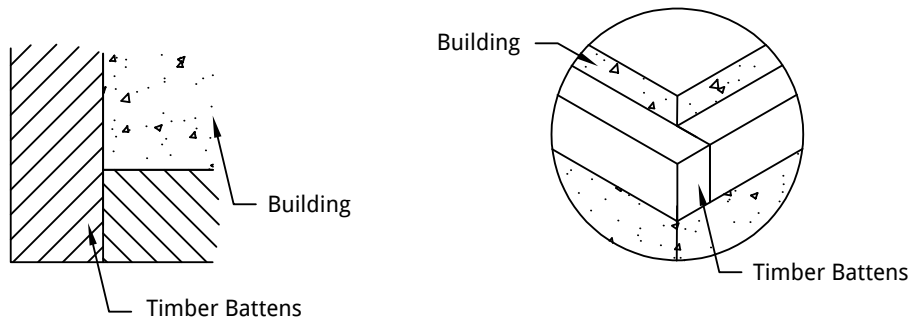

When using an Internal Corner Trim the timber battens need to finish as shown below.

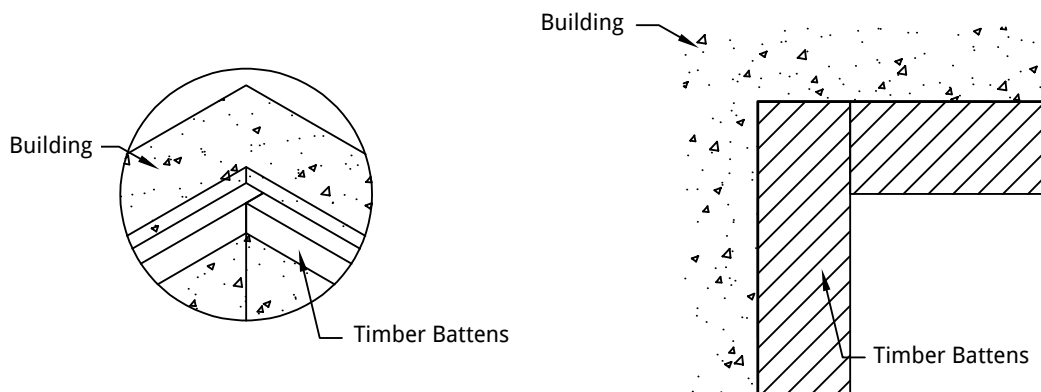

NOTE: Coastline cladding is designed for use on masonry buildings with a maximum height of 11m and installed at least 1m from boundaries.

6. FIXING OF FIRST TRIMS

6.0

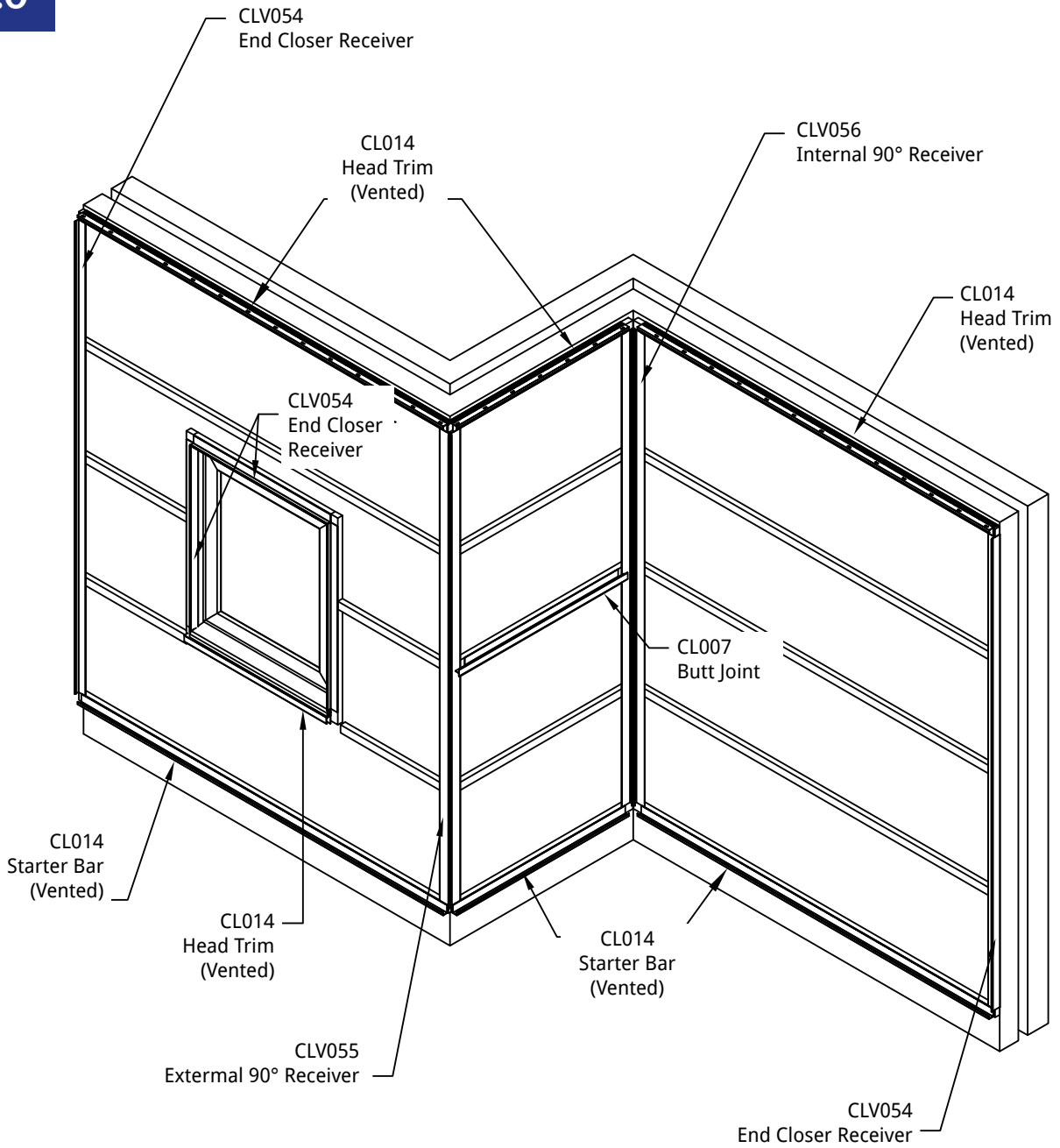

STARTER BAR AND HEAD TRIM DEDUCTIONS/ FITTING POSITIONS

Depending on the various installation requirements the Starter Bar and Head Trim sizes and locations differ. Please refer to the below deductions and diagrams for the various options (Cover Trims only showing as a visual aid to show various options, these will be installed later).

FITTED BETWEEN 2 END CLOSERS (CLV054)

6.1

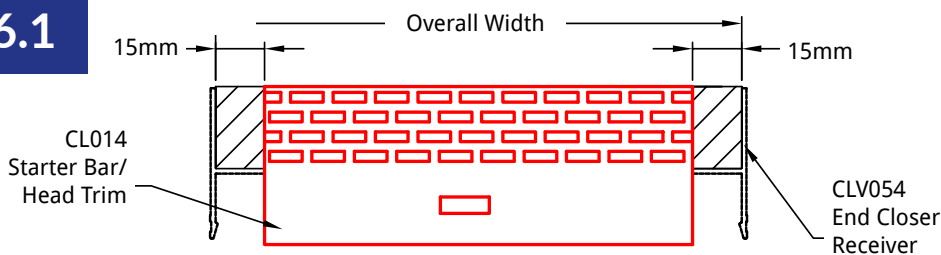

Full Width - 30mm.
Starter Bar/ Head Trim fixed 15mm inboard from edge of batten.

FITTED BETWEEN END CLOSER (CLV054) AND EXTERNAL 90 CORNER (CLV055)

6.2

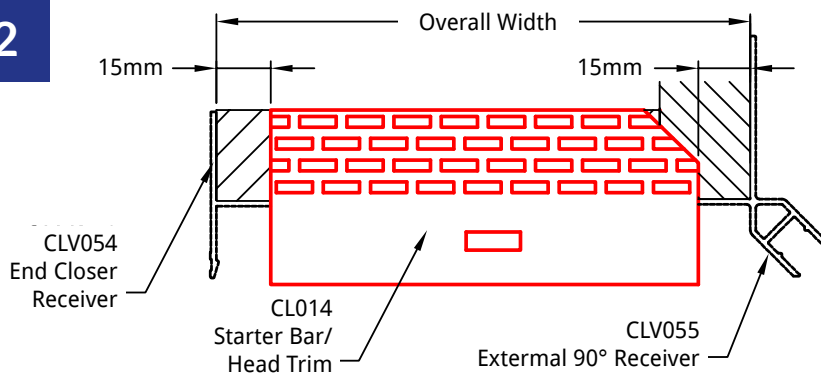

Full Width - 30mm.
Starter Bar/ Head Trim fixed 15mm inboard from the edge of the batten on the End Closer side.

FITTED BETWEEN END CLOSER (CLV054) AND INTERNAL 90 CORNER (CLV056)

6.3

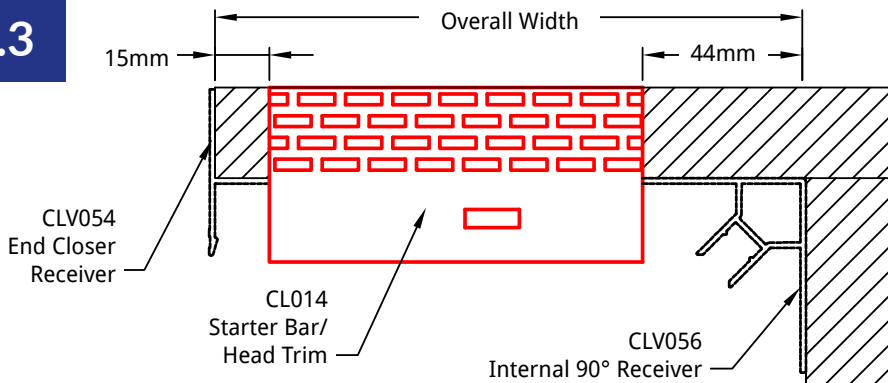

Full Width - 59mm.
Starter Bar/Head Trim fixed 15mm inboard from the edge of the batten on the End Closer side.

NOTE: Coastline cladding is designed for use on masonry buildings with a maximum height of 11m and installed at least 1m from boundaries.

FITTED BETWEEN 2 EXTERNAL 90 CORNERS (CLV055)

6.4

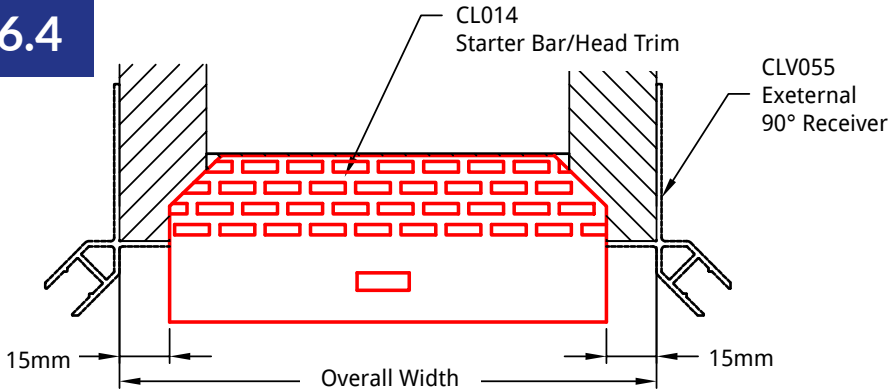

Full Width - 30mm.
Starter Bar/ Head Trim fixed 15mm inboard from the edge of the batten.

FITTED BETWEEN 2 INTERNAL 90 CORNERS (CLV056)

6.5

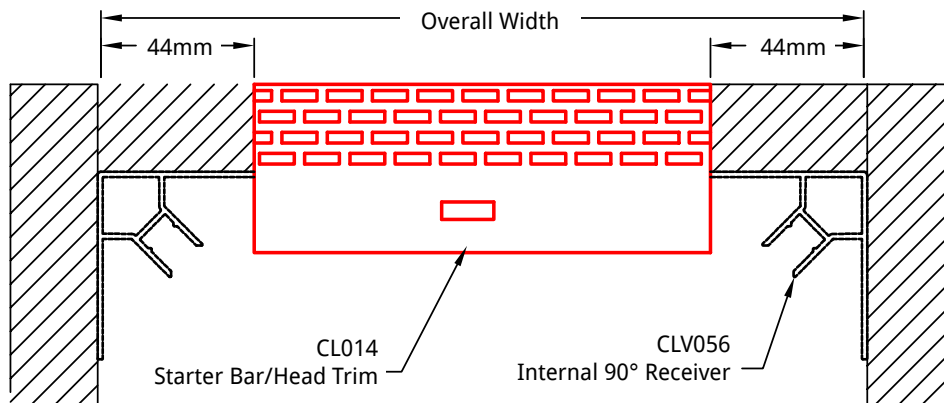

Full Width - 88mm. Starter Bar/ Head Trim fixed 44mm from edge of batten.

FITTED TO UNDERSIDE OF CILL

6.6

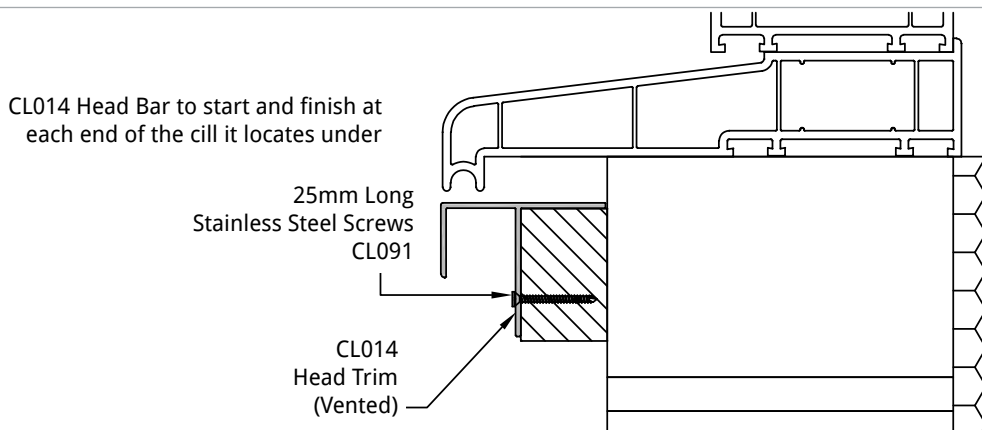

Starter/Head Trim CL014 should run the same length as Cill it locates under.

STARTER BAR - EXTERNAL 90 ADDITIONAL PREPARATION

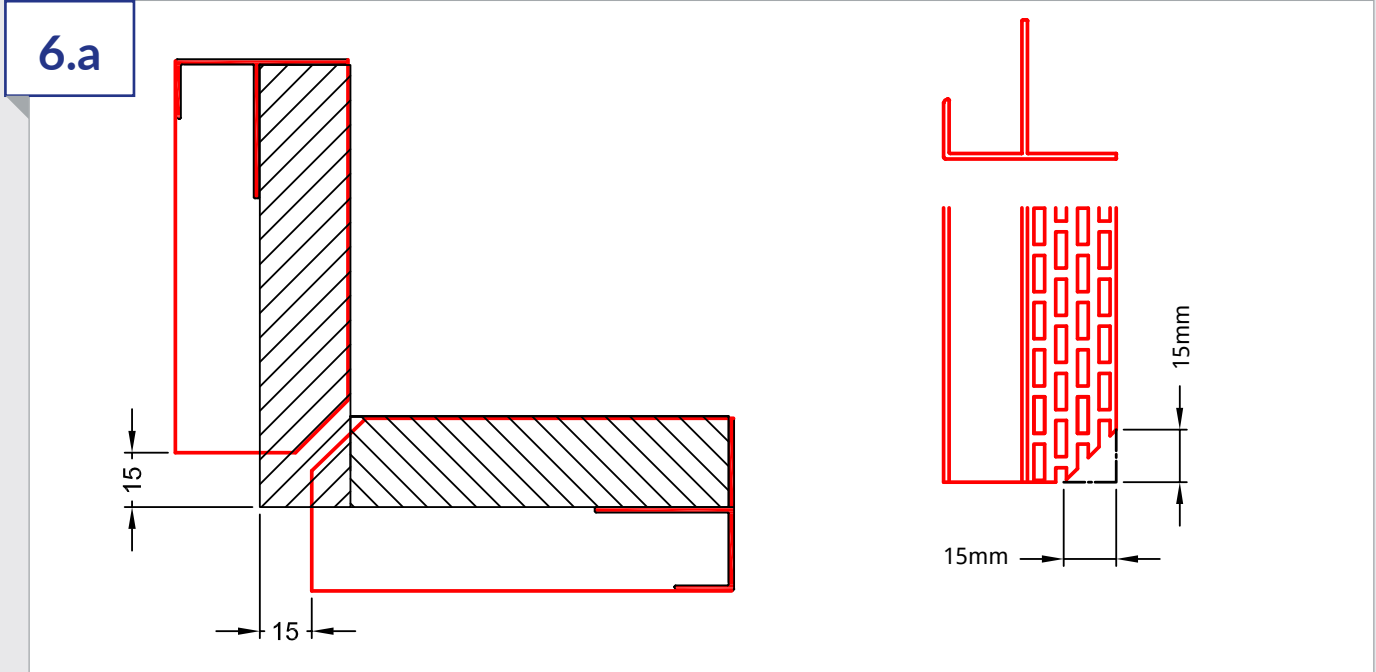

Where an External Corner (CLV055/65) is being used the Starter Bar (CL014) will require a small mitre cut at the External Corner end so that the Starter bar does not interfere with each other when fitting.

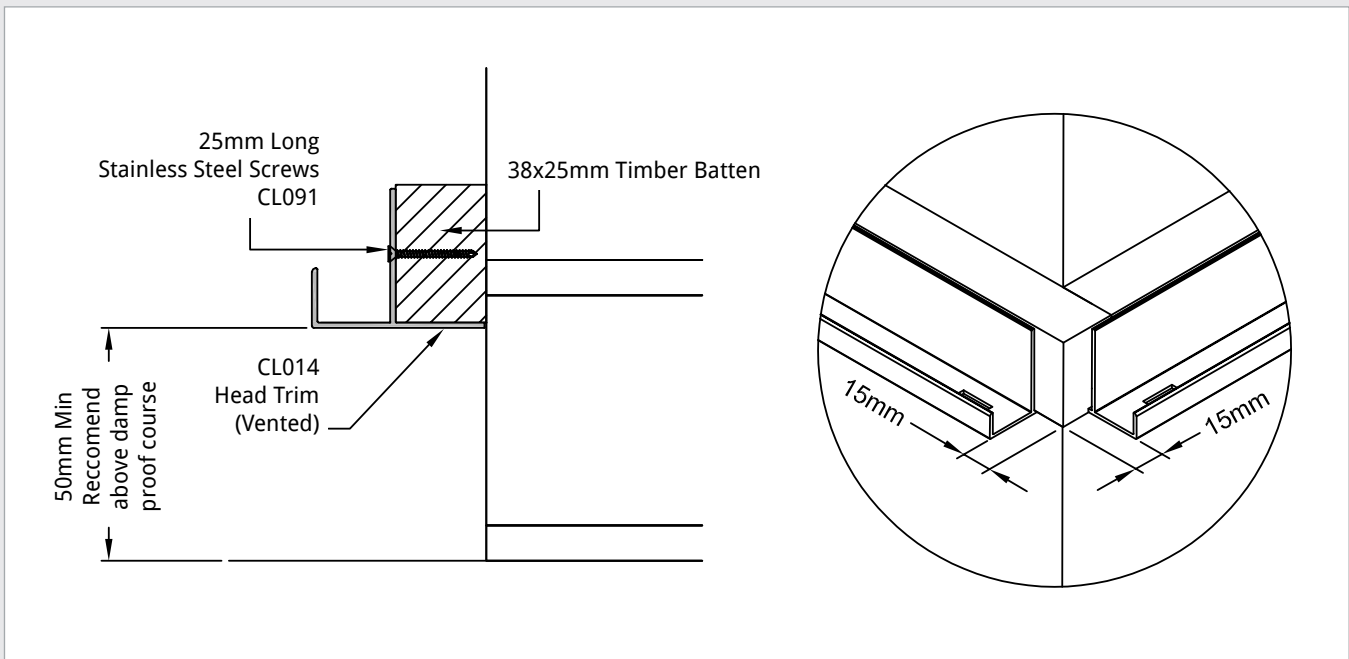

Fit the Starter Bar (CL014) to the bottom of the timbers, fix back to the batten as shown using 25mm stainless screws at approximately 500mm centres.

NOTE: Coastline cladding is designed for use on masonry buildings with a maximum height of 11m and installed at least 1m from boundaries.

HEAD TRIM - EXTERNAL 90 ADDITIONAL PREPARATION

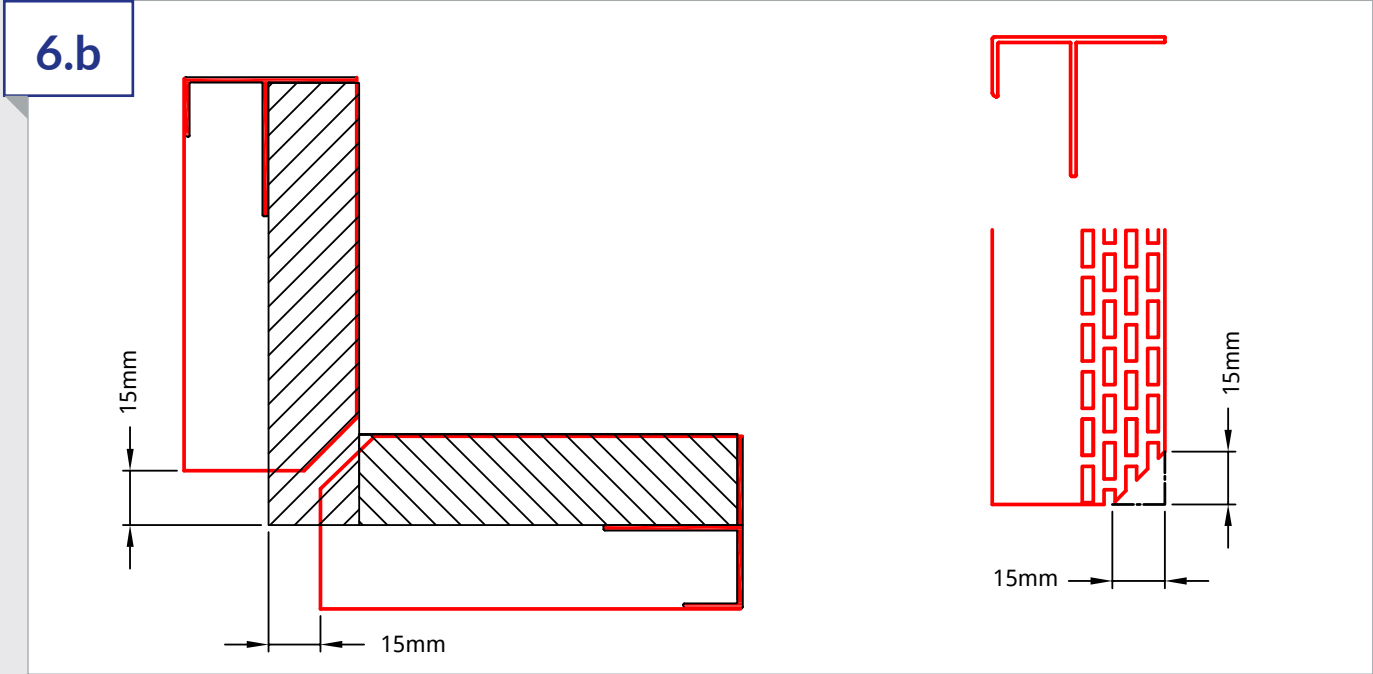

Where an External Corner (CLV055/65) is being used the Head Trim (CL014) will require a small mitre cut at the Internal Corner end so that the Head Trims do not interfere with each other when fitting.

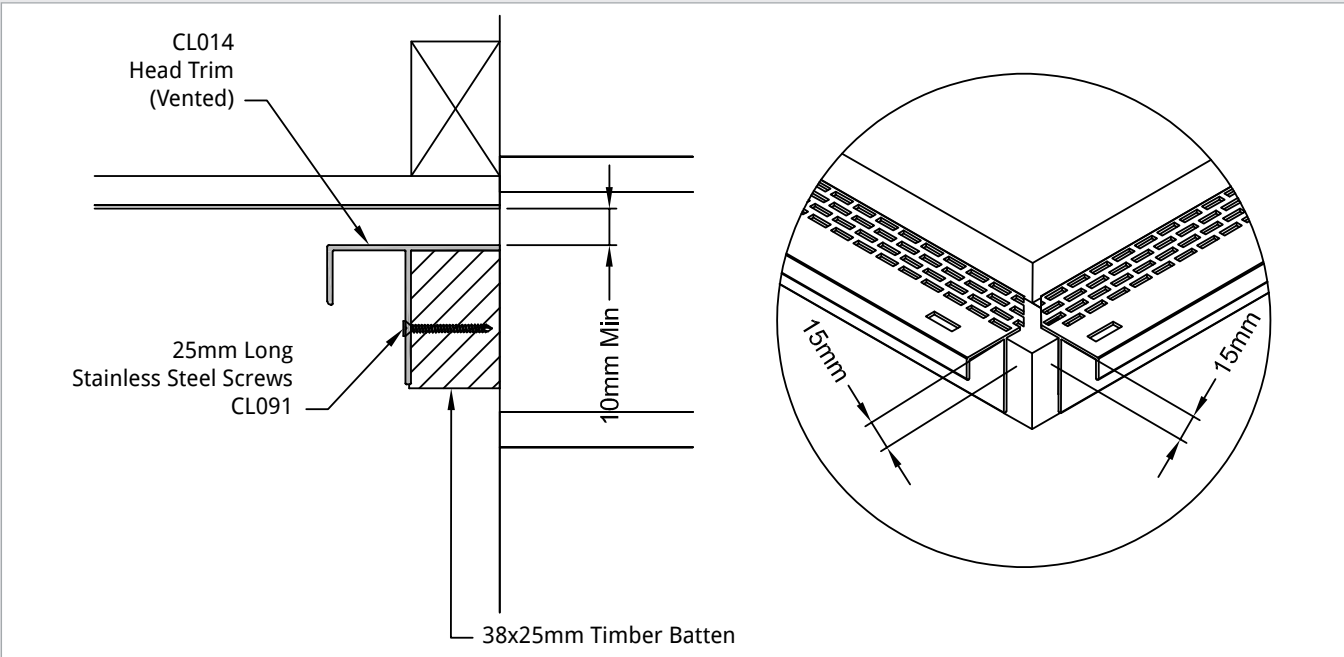

Fix Head Trim (CL014) to the top timber batten, using 25mm stainless steel screws at approximately 500mm centres.

STARTER BAR/HEAD TRIM WHEN USING INTERNAL CORNER TRIM

6.7

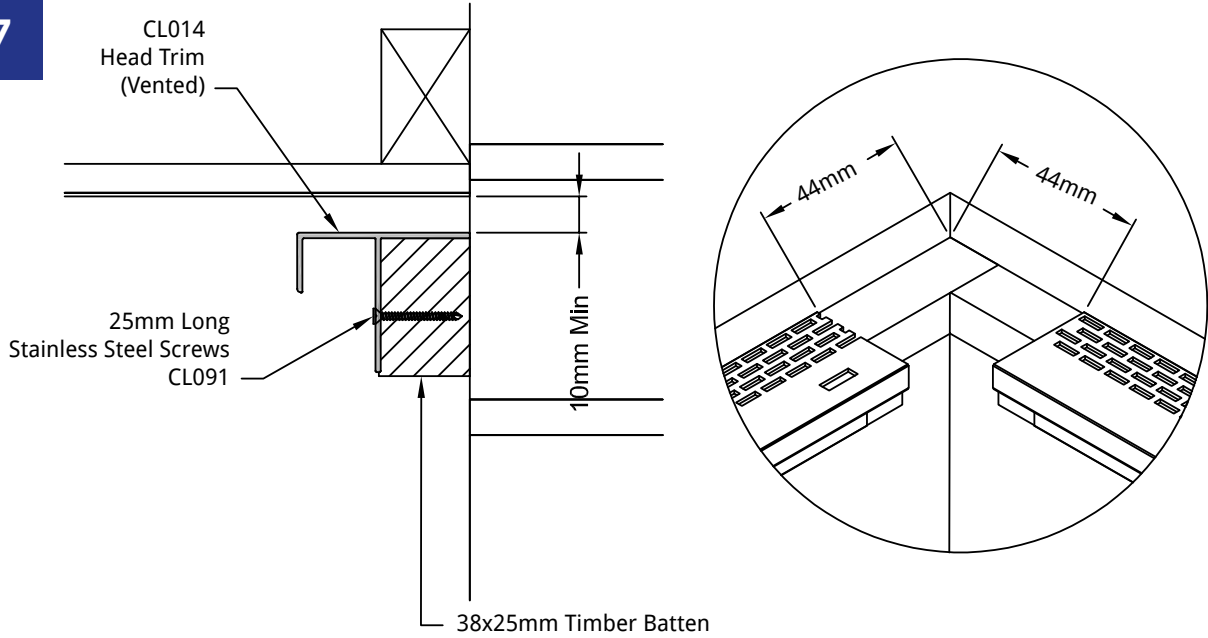

Where an Internal Corner (CLV056/66) is being used the Head Trim (CL014) will require square cutting short to ensure ease of fitting the Internal 90 Cover Trim.

6.8

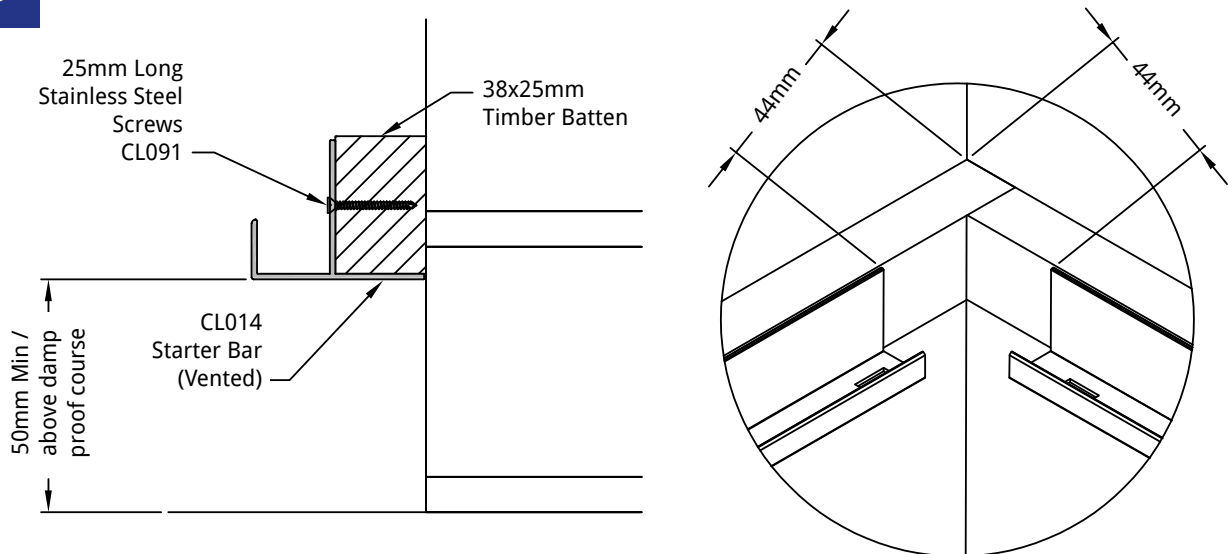

Where an Internal Corner (CLV056/66) is being used the Starter Bar (CL014) will require square cutting short to ensure ease of fitting the Internal 90 Cover Trim.

NOTE: Coastline cladding is designed for use on masonry buildings with a maximum height of 11m and installed at least 1m from boundaries.

END CLOSER PREPARATION

6.9

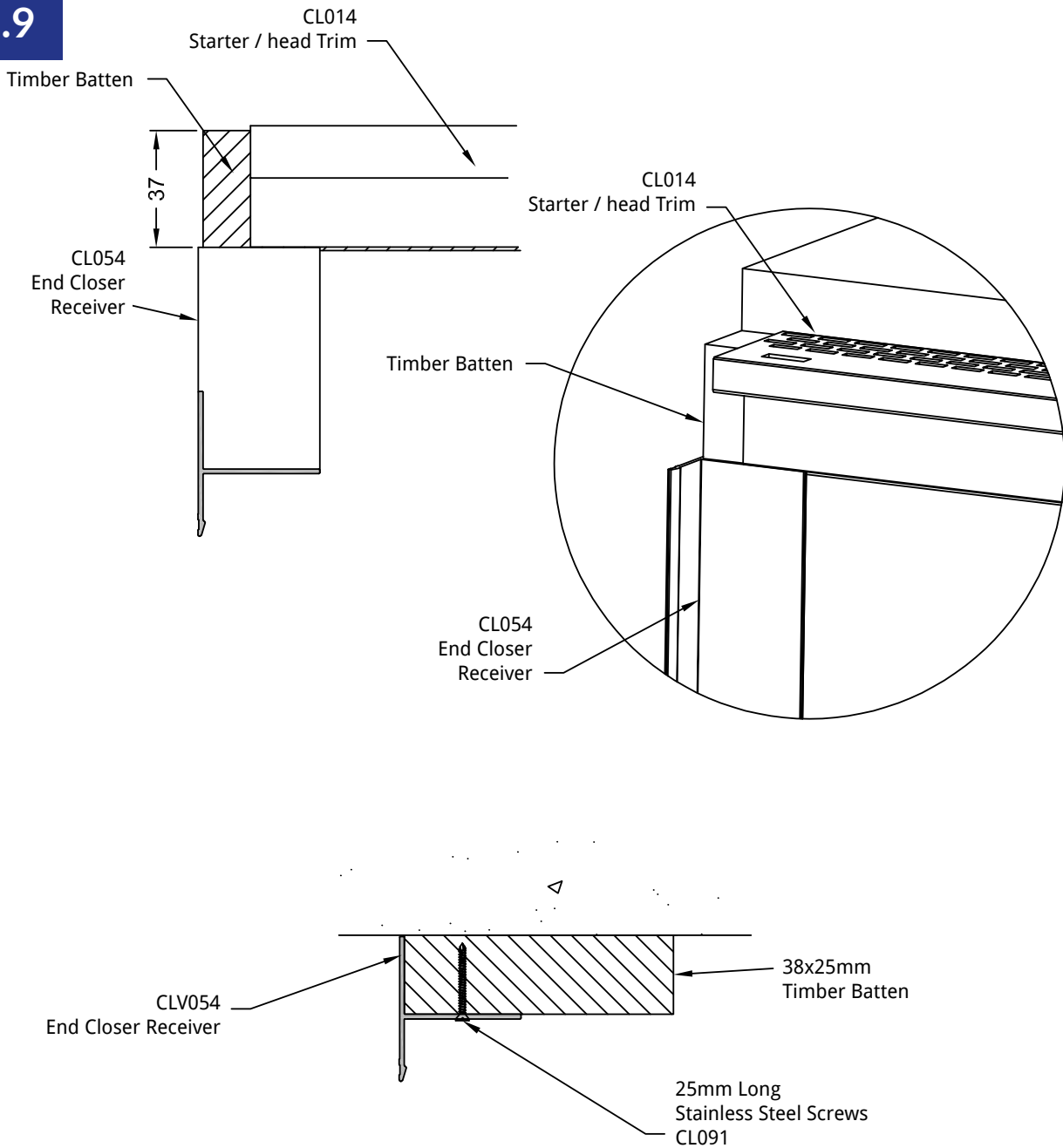

To cut the End Closer Receiver to the correct length, measure the distance from the top of the head timber batten to the bottom of the starter bar timber batten - 74mm (37mm short at each end).

Once cut to size locate the End Closer Receiver (CL054) onto the timber batten, fix using 25mm stainless steel screws. Position the Receiver so that it is 37mm down from the top of the timber batten as shown above.

EXTERNAL CORNER RECEIVER

6.10

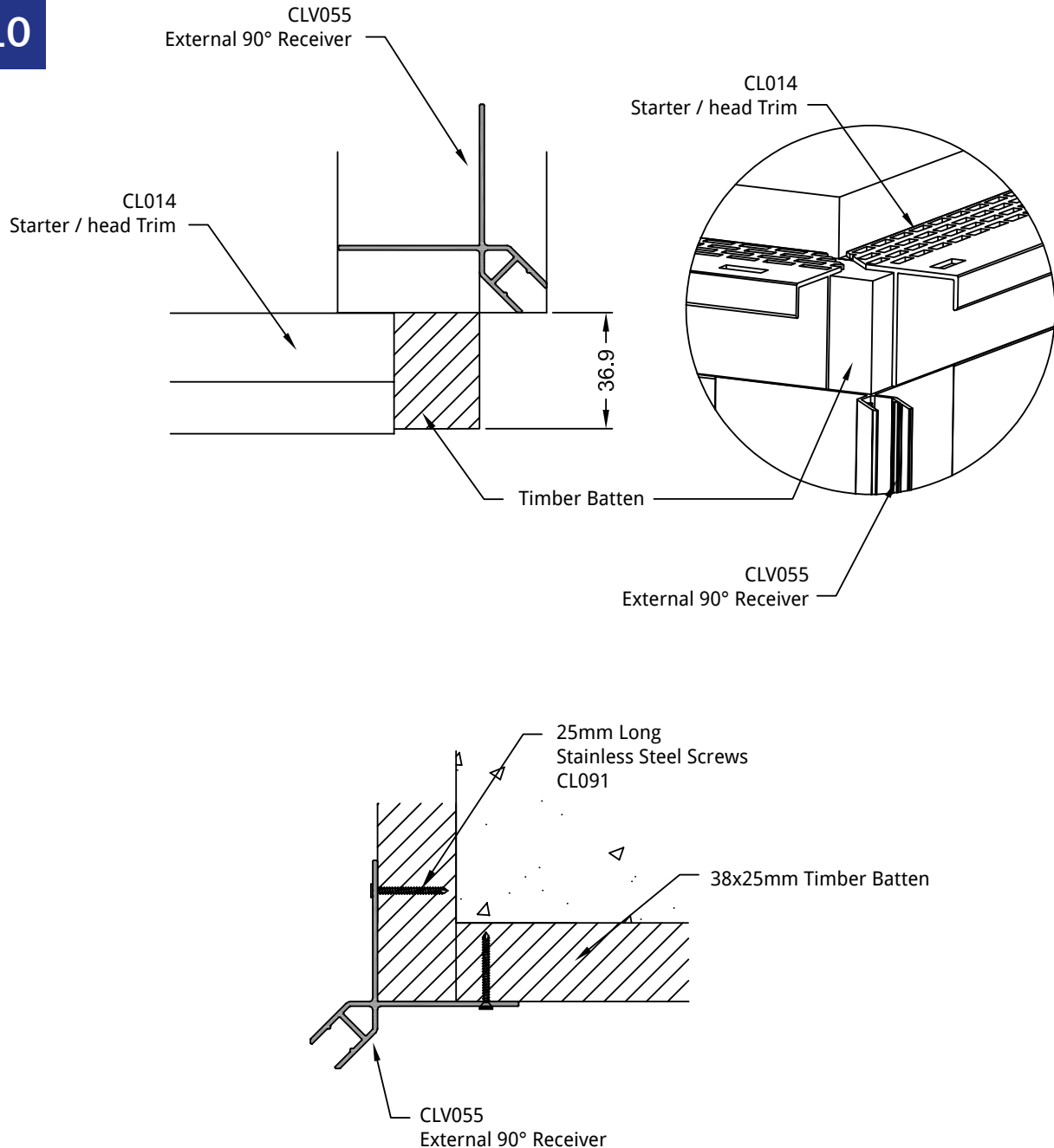

To cut the External 90 Receiver (CLV055) to the correct length, measure the distance from the top of the head timber batten to the bottom of the starter bar timber batten - 74mm (37mm short at each end).

Once cut to size locate the External 90 Receiver (CLV055) onto the timber batten, fix using 25mm stainless steel screws but only fix on one side of the Receiver to ensure the angle does not alter. Position the Receiver so that it is 37mm up from the bottom of the Starter Bar timber batten as shown above.

INTERNAL CORNER RECEIVER

6.11

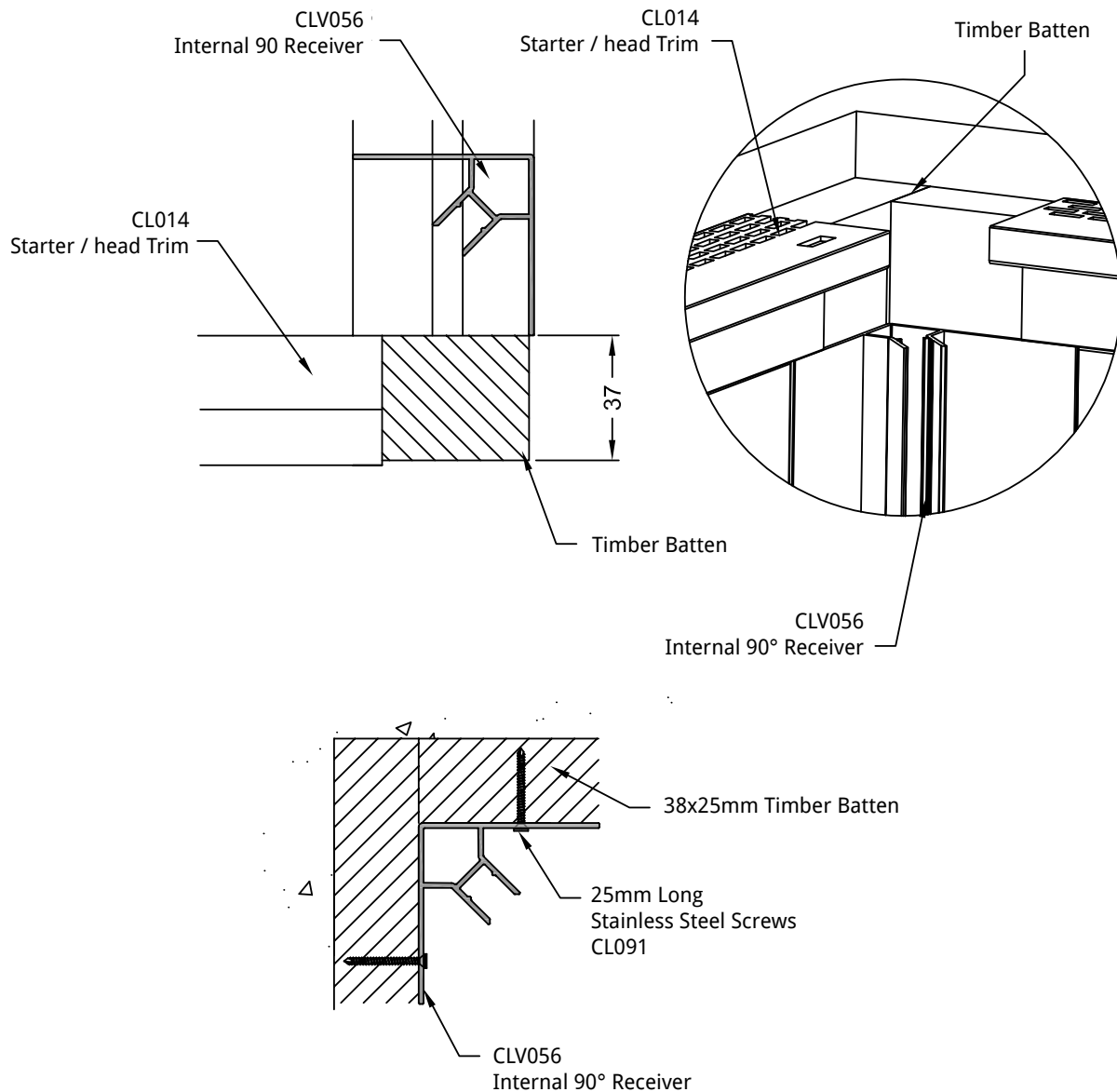

To cut the Internal 90 Receiver (CLV056) to the correct length, measure the distance from the top of the head timber batten to the bottom of the starter bar timber batten - 74mm (37mm short at each end).

Once cut to size locate the Internal 90 Receiver (CLV056) onto the timber batten, fix using 25mm stainless steel screws but only fix on one side of the Receiver to ensure the angle does not alter. Position the Receiver so that it is 37mm up from the bottom of the Starter Bar timber batten as shown above.

WINDOW REVEAL TRIMS

6.12

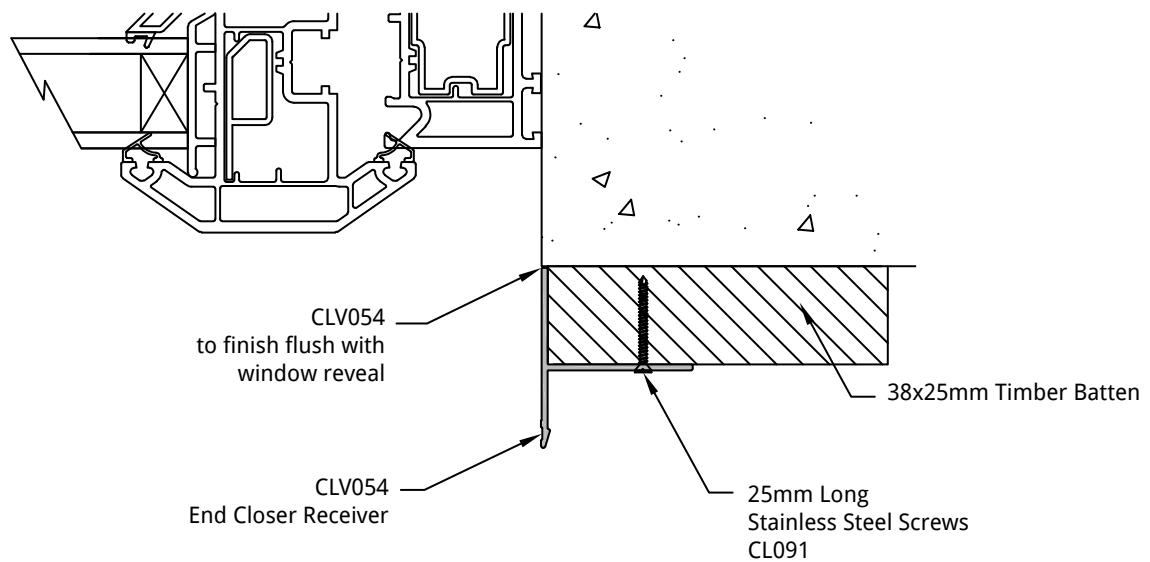

The End Closer Receiver (CLV054) needs to be fitted before installation of the cladding board begins. These Trims will be fitted to the sides and the head of the window.

7. CLADDING BOARD FIXING METHOD

7.0

To begin the installation of the coastline cladding planks, locate the first plank onto the Starter Bar (CL014) and position into Corner Trim/ End Closer Receiver fixing along the horizontal timber battens using 25mm stainless steel nails (CL090) or 25mm Stainless Steel Screws (CL091) fixing back to each timber batten (max 500mm centres).

INTERNAL CORNER

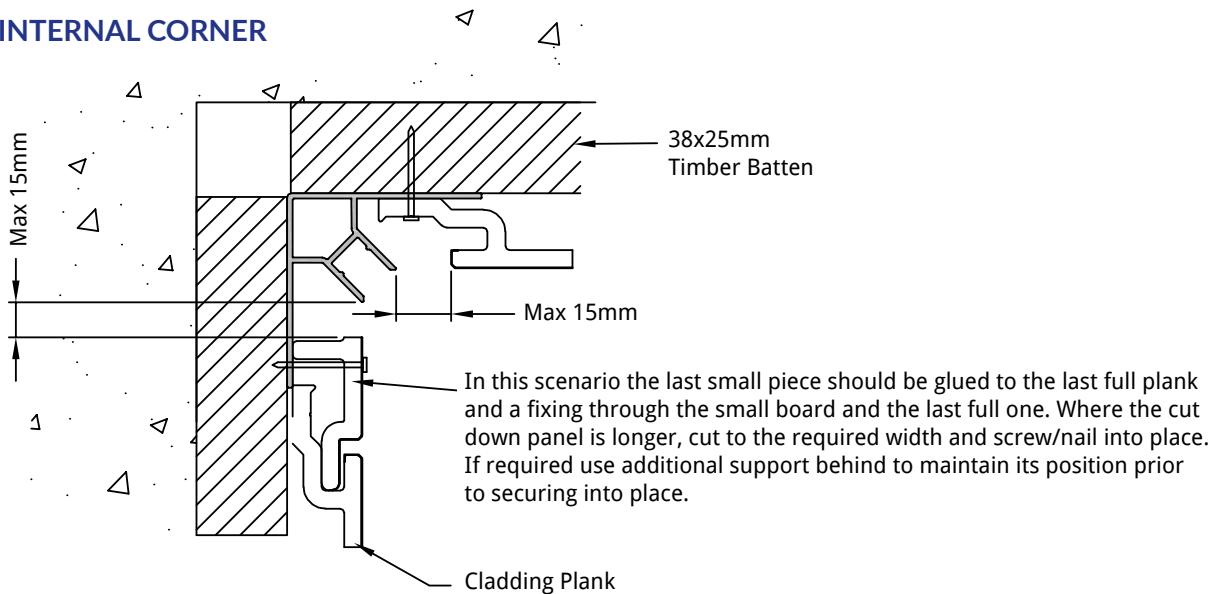

EXTERNAL CORNER

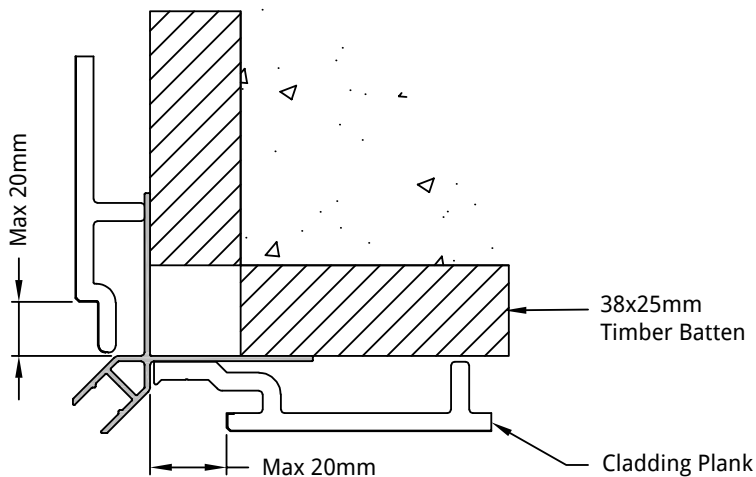

END CLOSER

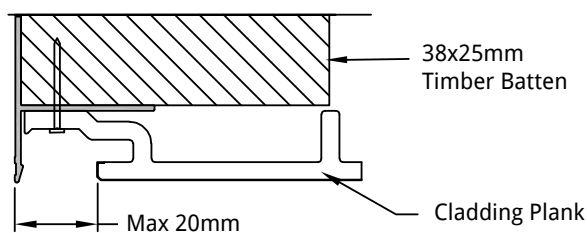

CLADDING BOARD FIXING METHOD

7.1

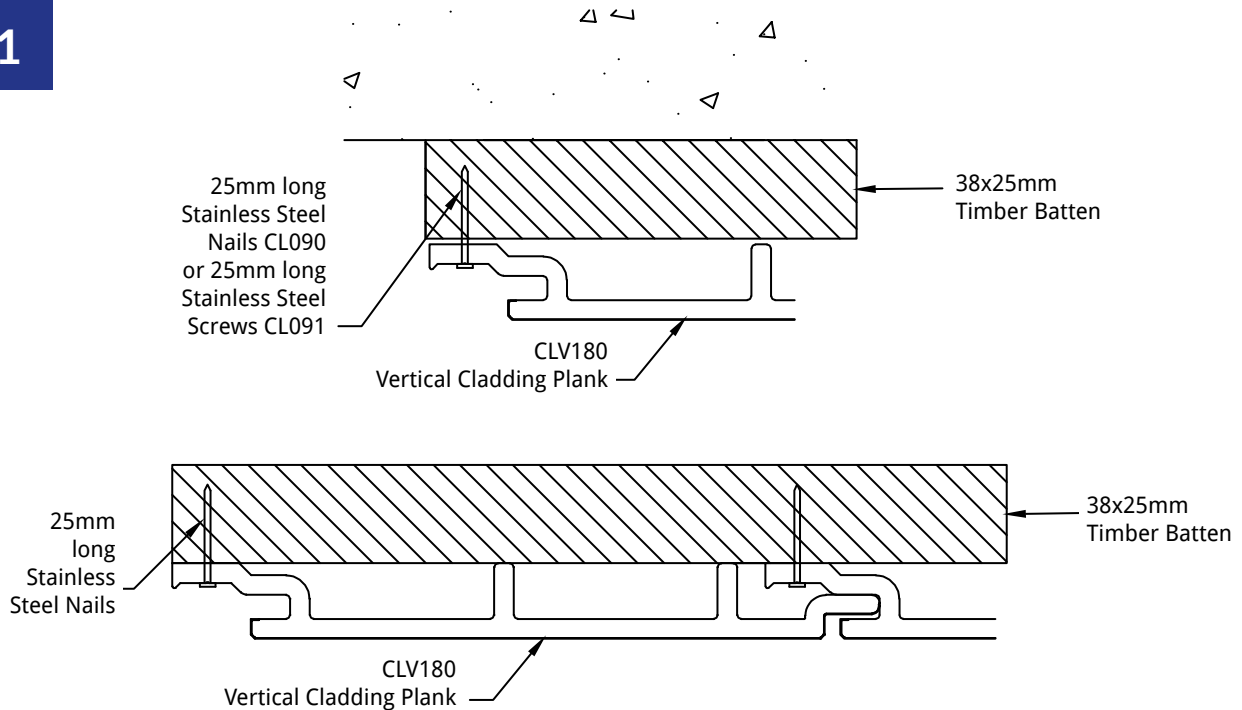

Once secure hook in the next cladding plank hiding the fixings of the first board, as before fix back to the timbers. Continue this method until the cladding is complete.

7.2

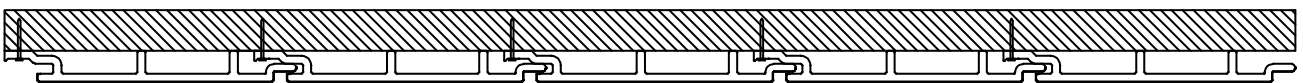

Once all board are located and fixed to the timber battens the Corner Trims can be pushed onto the Corner Receivers to finish off the installation.

7.3

AROUND WINDOW

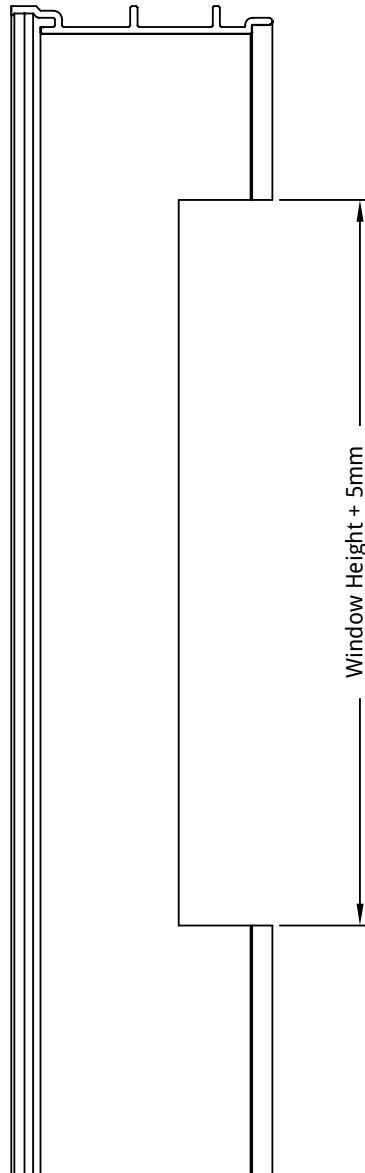

If cladding runs around a window, planks may need notching around the window at both sides. The size of the notch is dependant on the window size and where the planks locate. Below is an example of possible notching details for around the window. A packer may be required behind the notched board to aid fixing. Window reveal trim can be used on the notched section to make a neater finish.

8. END CLOSER - COVER TRIM

8.0

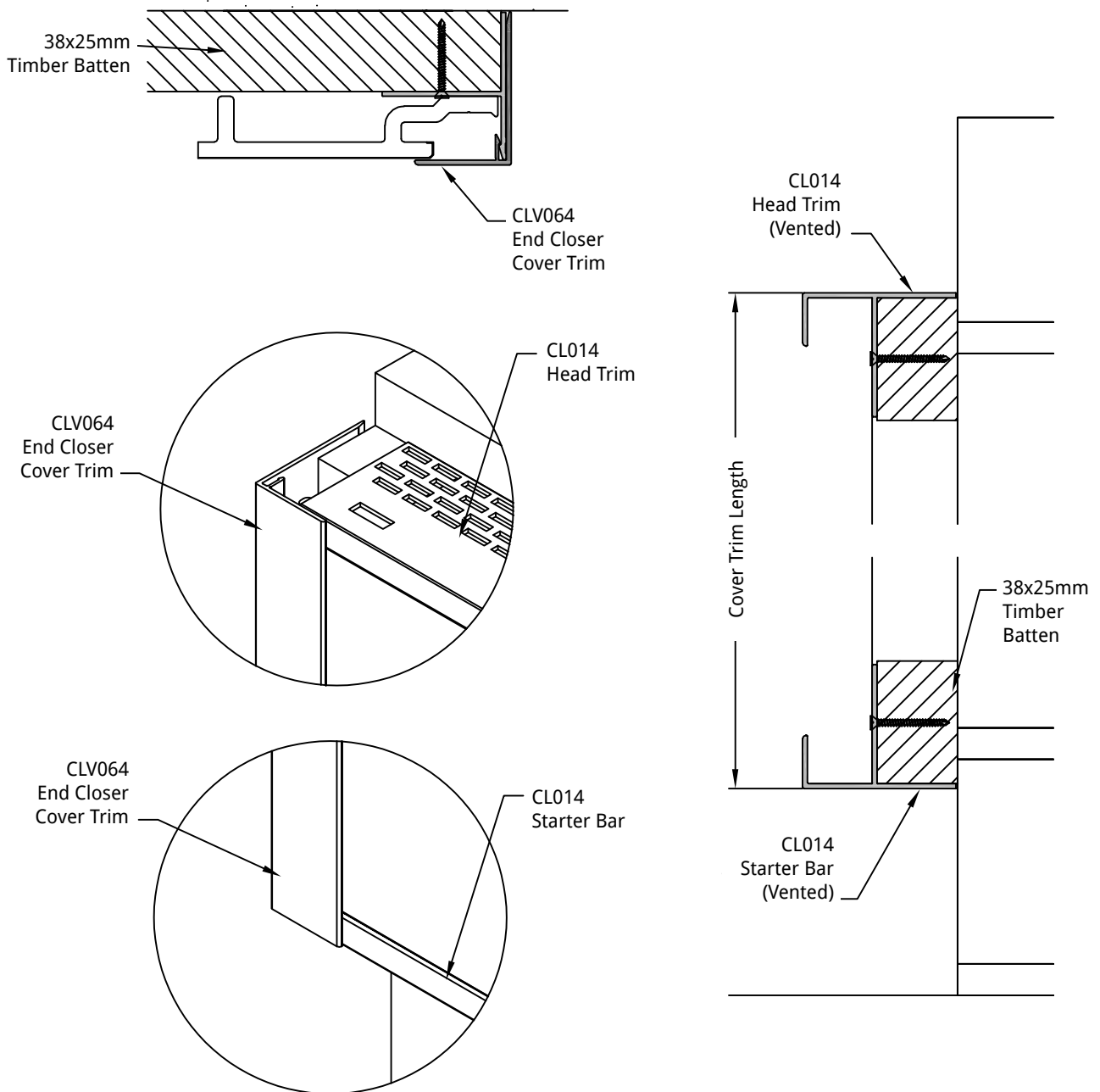

Once all boards are in position the Cover Trims can now be fitted.

Cut the End Closer Cover Trim (CLV064) to size, measure from the top of the head trim to the bottom of the Starter bar.

Push locate the End Closer Cover Trim into position and use a rubber mallet to tap into place to ensure a secure fit.

The End Closer Cover Trim should pass over the Head Trim and Starter Bar.

It is recommend that the external cover trim (CLV064) has a single mechanical fixing (suitable screw at any point over the length of the trim) securing it to the receiver (CLV054) where a install goes beyond 3m above the external floor level.

NOTE: Coastline cladding is designed for use on masonry buildings with a maximum height of 11m and installed at least 1m from boundaries.

EXTERNAL 90 CORNER COVER TRIM

8.1

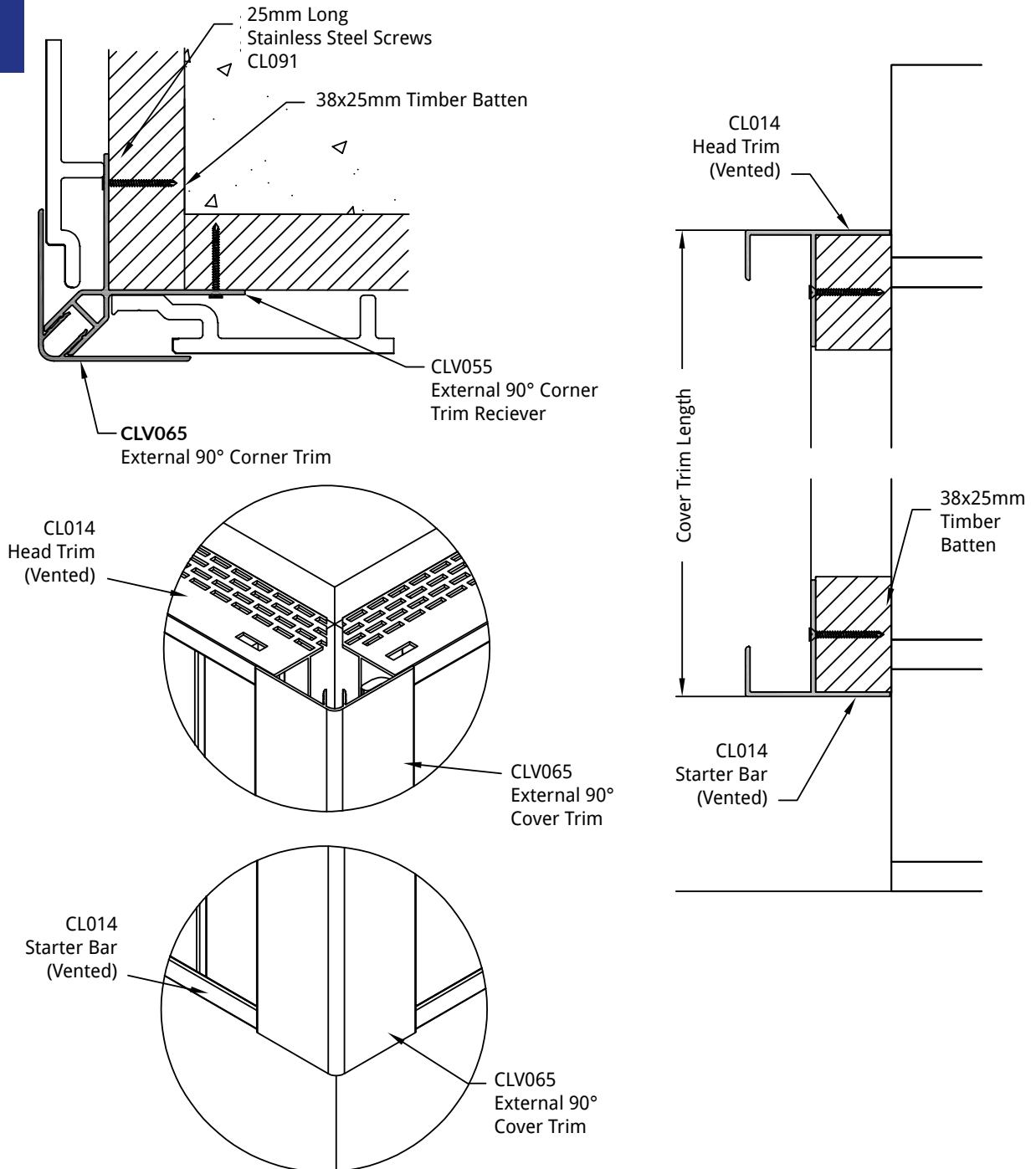

Once all boards are in position the Cover Trims can now be fitted.

Cut the External 90 Cover Trim (CLV065) to size, measure from the top of the head trim to the bottom of the Starter bar.

Push locate the External 90 Cover Trim on the the receiver and use a rubber mallet to tap into place to ensure a secure fit. The External 90 Cover Trim should pass over the Head Trim and Starter Bar.

It is recommend that the external cover trim (CLV065) has a single mechanical fixing (suitable screw at any point over the length of the trim) securing it to the receiver (CLV055) where a install goes beyond 3m above the external floor level.

INTERNAL 90 CORNER COVER TRIMS

8.2

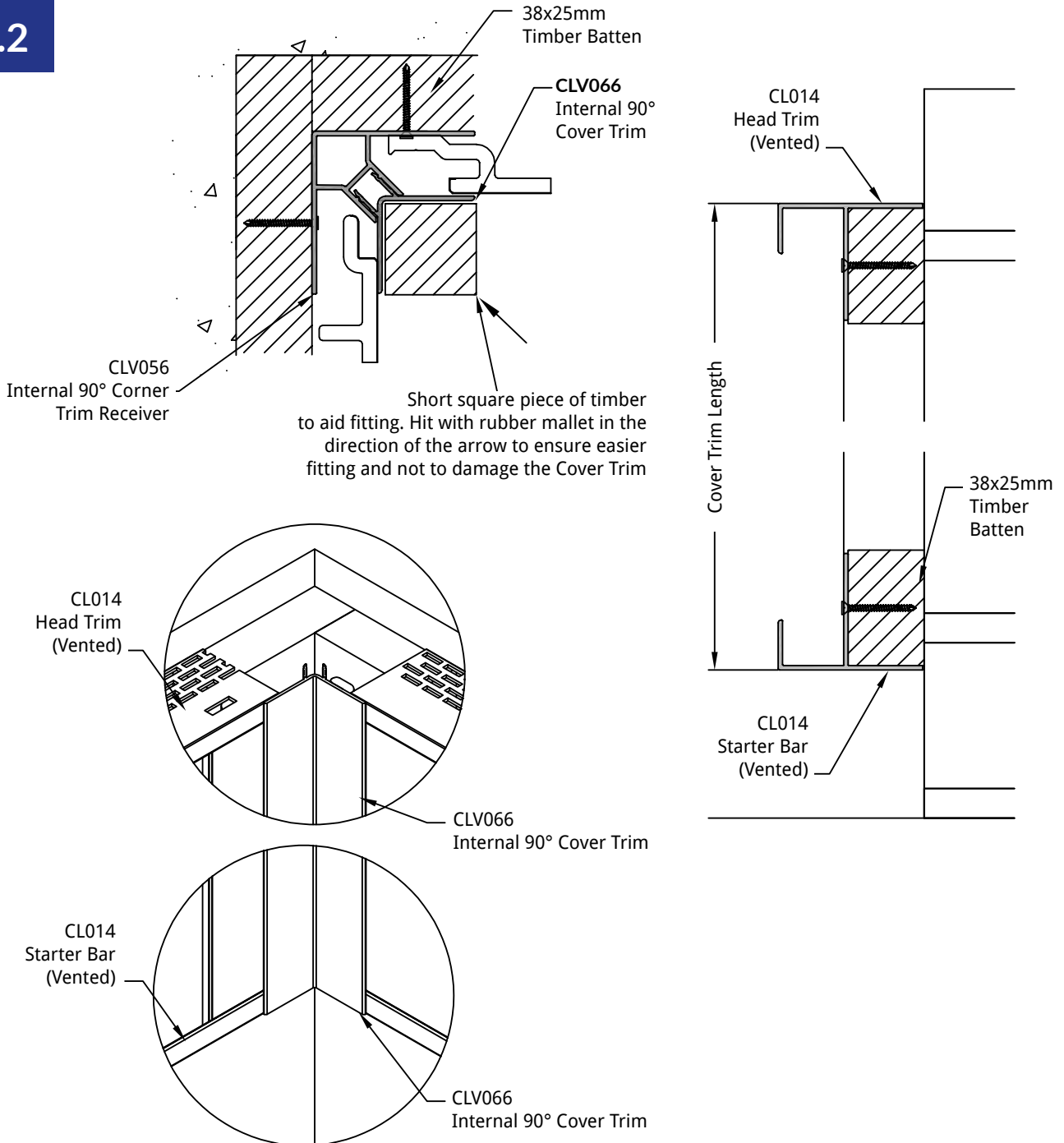

Once all boards are in position the Cover Trims can now be fitted.

Cut the Internal 90 Cover Trim (CLV065) to size, measure from the top of the head trim to the bottom of the Starter bar.

Push locate the Internal 90 Cover Trim into position and use a timber block and rubber mallet to tap into place to ensure a secure fit.

The Internal 90 Cover Trim should pass over the Head Trim and Starter Bar.

It is recommend that the Internal 90 cover trim (CLV066) has a single mechanical fixing (suitable screw at any point over the length of the trim) securing it to the receiver (CLV056) where a install goes beyond 3m above the external floor level.

NOTE: Coastline cladding is designed for use on masonry buildings with a maximum height of 11m and installed at least 1m from boundaries.

WINDOW REVEAL COVER TRIMS

8.3

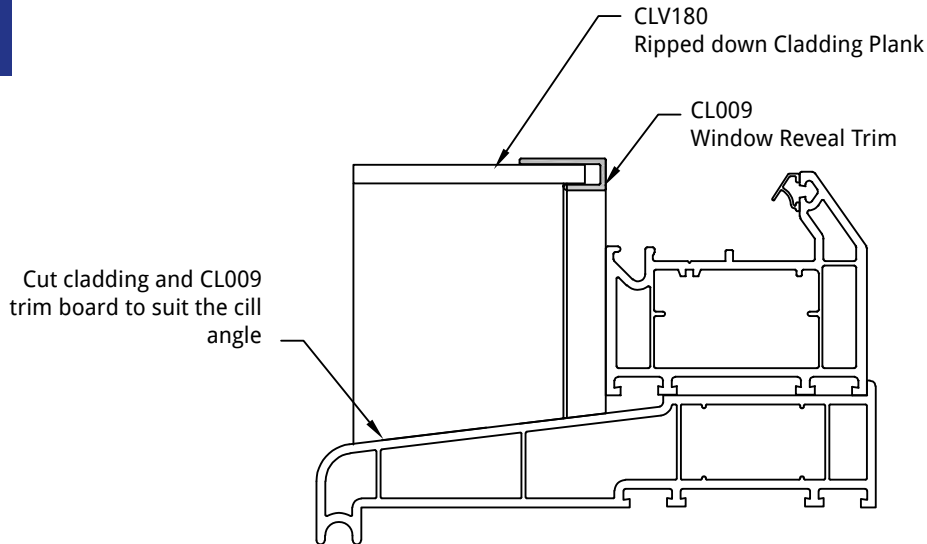

Once all boards are in position the Window reveal can be trimmed up and Cover Trims be fitted.

Cut the Window Reveal Cover Trim (CLV058) vertical sections to size, measure the window reveal Height+ 38mm and mitre the corners to ensure a neat finish.

Cut down a Cladding Plank (CLV180) to fit the window reveals, leaving a 5mm flat board section to fit within the trims. The cut down cladding plank will need cutting to suit the cill detail as shown above.

Cut to size and slide the Window Reveal Trim (CL009) onto the cut down plank. The pieces that run up the sides will need cutting to suit the cill as shown above.

8.4

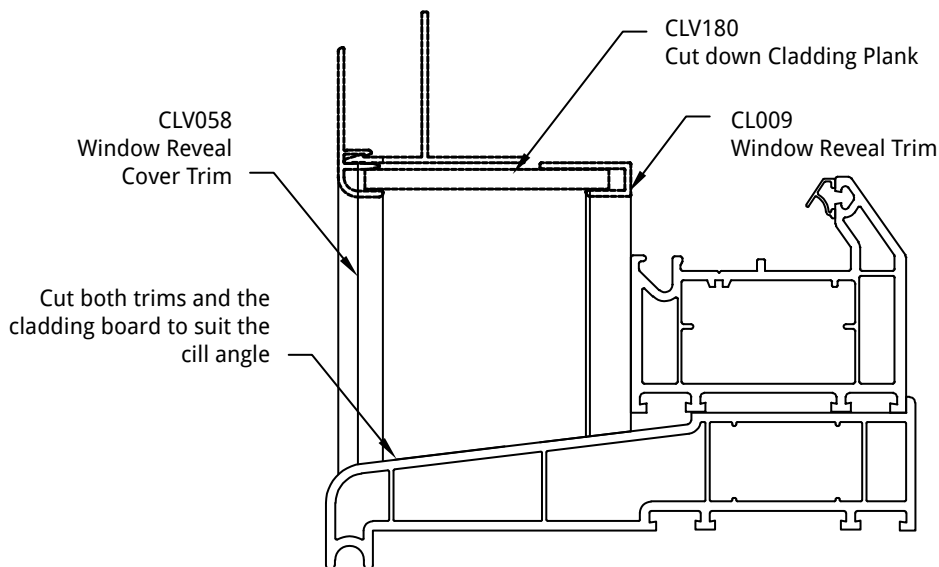

Cut the Window Reveal Cover Trim (CLV058) vertical sections to size, measure the window reveal Height+ approx 38mm and mitre the corners to ensure a neat finish. The trim that runs up the side will need cutting to suit the CIII so cutting size may vary.

WINDOW REVEAL COVER TRIMS

8.5

Offer up into position the cladding plank complete with CL009 trim up the sides of the reveal ensuring the cut down board is located as shown below. Now fit the Window Reveal Corner Trim (CLV058) using a rubber mallet into position on the End Closer Receiver (CLV054). Once correctly located fix through the board and into the timber batten or use suitable adhesive to hold the plank in place.

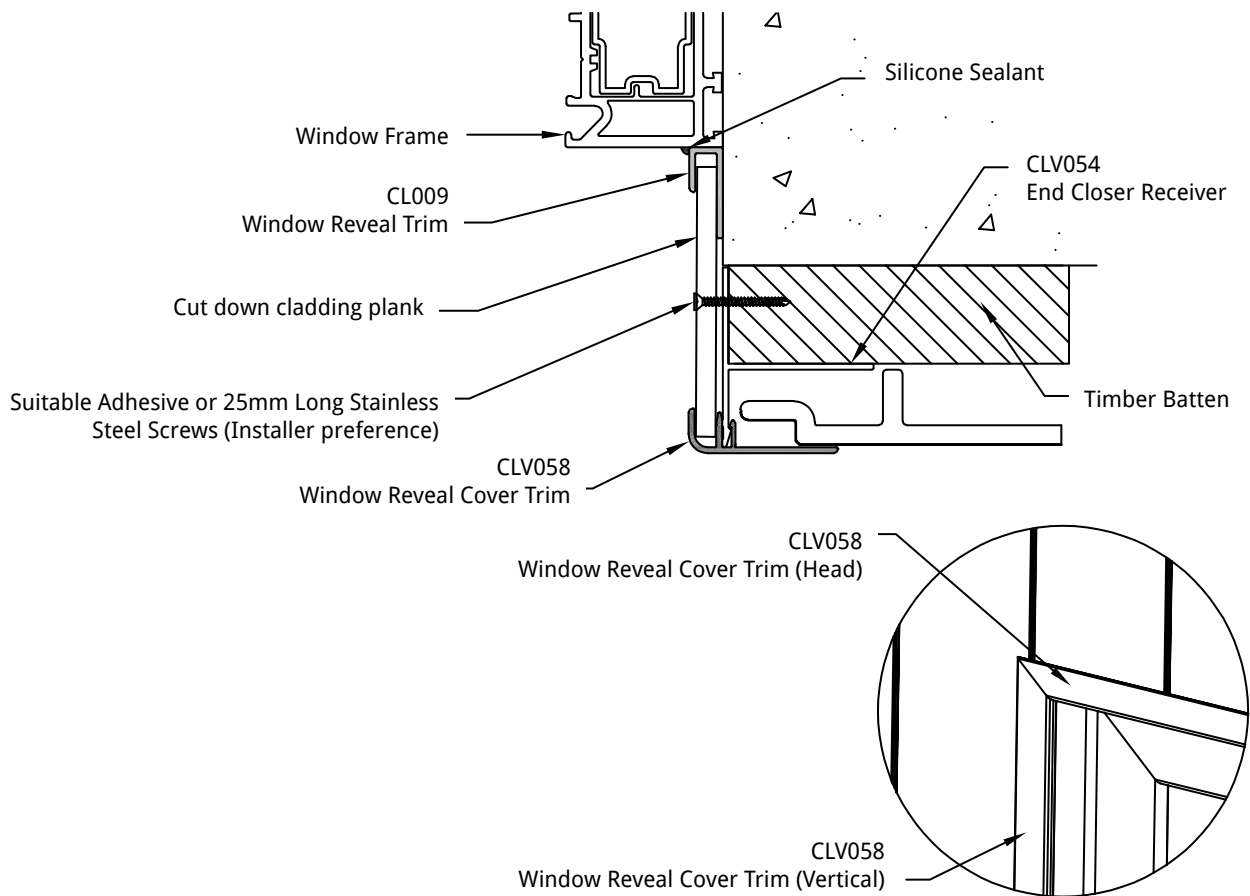

Now cut the Window Reveal Cover Trim for the head section, measure the overall distance from the outer edges of the fitted vertical sections and cut to this size, mitre the section at both ends to suit.

BUTT JOINT

8.6

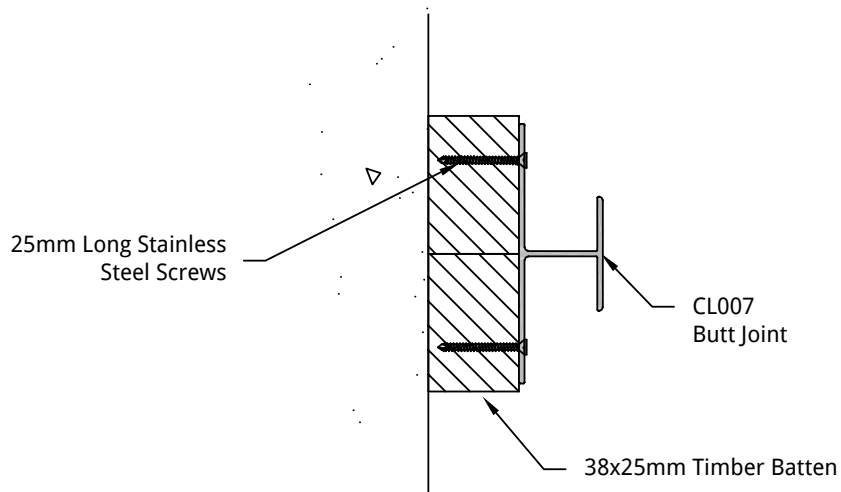

Where a butt joint is required, 2 vertical timbers are required to allow the butt joint to be fixed. Using stainless steel screws fix at 300mm centres. Square cut at both ends between the Cover Trims as required.

END PLATE DETAILS

8.7

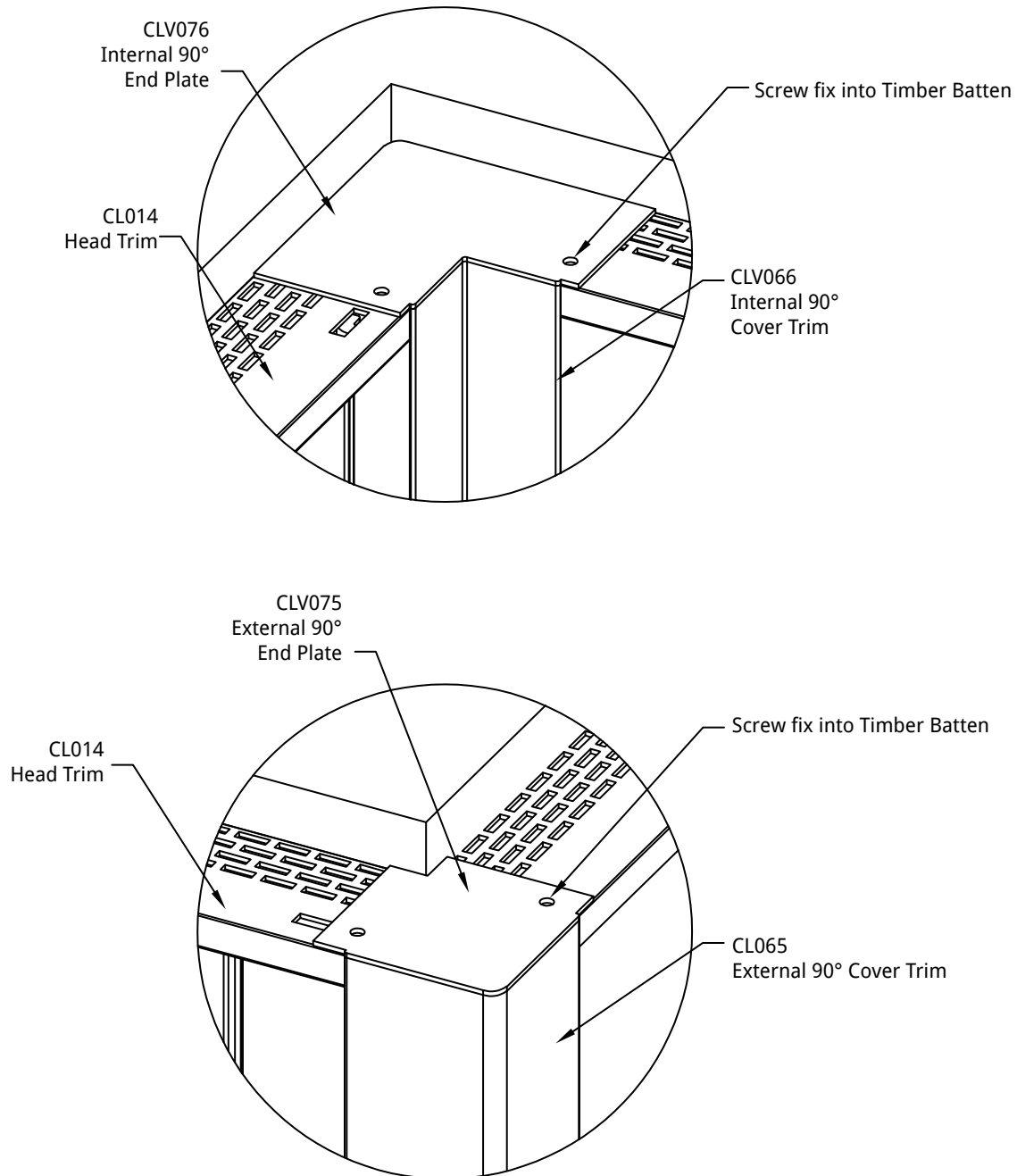

It is recommended End Plates are used where the underside of the Starter bar or top of the Head Trim will be visible on completion of the installation.

Where Internal and External Corner Trims (CLV055/56 & CL065/66) are used, screwported End Caps (CLV075 & CLV076) are available. These are to be fitted by offering up to the end of the corner trim and screwing into the timber battens.

NOTE: Coastline cladding is designed for use on masonry buildings with a maximum height of 11m and installed at least 1m from boundaries.

9. FINAL INSPECTION - THINGS TO LOOK FOR

Check that appropriate trims have been used in the correct location. Check that adequate expansion and contraction tolerances have been observed. (4/5mm at each board end). Ensure fixing centres are correct. Check for the air space behind the cladding. No obstructions should exist behind the cladding system e.g. thermal insulation fixed behind the system. Check that correct fixings have been used to fix the cladding profiles. For e.g. 25mm x 2.65mm gauge (A4 grade) stainless steel nails at each intersection. Check that all joints have been planned to give a neat symmetrical and balanced appearance and are made over support battening. Ensure window intersections are watertight and trimming has been completed neatly.

10. GENERAL MAINTENANCE

Coastline profiles are self-finished and low maintenance. Occasional washing with a non-abrasive mild detergent and water is beneficial in removing surface grime and maintaining a pristine appearance, especially in heavily polluted atmospheres.

Solvents should not be used under any circumstances for cleaning.

Exercise care to prevent contact with, and staining by creosote or bitumen-based products.

Many common building materials can be easily cleaned off without damage.

11. SURFACE REPAIR

Prior to surface repair advice should be sought from the manufacturer regarding continuity of guarantees.

Coastline Boards are designed to be a 'through colour' product therefore minor scratches or scores should not be visible, however colour matched touch up pens and silicone sealants are available from the point of purchase should any cosmetic repairs be required to trims and joints.

12. BOARD REPLACEMENT PROCEDURES

Replacement of a single board can be achieved; alternatively removal of the affected boards may require removal of trims and nails in and around the area of damage. Check battens, waterproof breathable membrane, and substrate and repair as necessary.

PRE-INSTALLATION CHECK

- ▶ **Coastline cladding is designed for use on masonry buildings with a maximum height of 11m and installed at least 1m from boundaries.**



Failure to install Coastline in accordance to these instructions will invalidate the Product Guarantee.

**Full
product
range**



Deeplas Roofline



Coastline Lightweight Composite Cladding



Equinox Tiled Roof System



Skypod Lantern Roofs



Twinson Premium Cladding



Internal Wall and Ceiling Panels

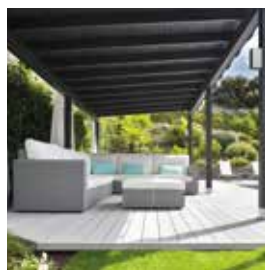

Twinson Decking



Roomline PVC-U Skirting



Deeplas Embossed Cladding



Slateskin GRP Sheet Tile System



Deeplas Window Boards



Rainwater



Shower Panels



Garden Rooms

Customer service

If you need any assistance, please call the Customer Services team on the following number or visit deeplas.co.uk



0800 988 7309